

EPEVER

LS-E Series

— **Solar Charge Controller**

USER

MANUAL

LandStar

LS-E Series

— Solar Charge Controller



Nominal System Voltage	LS0512E/LS1012E	12VDC
	LS1024E/LS2024E	12/24VDC
Maximum PV Input Voltage	LS0512E/LS1012E	30V
	LS1024E/LS2024E	50V
Nominal Charge/Discharge Current	LS0512E	5A
	LS1012E/LS1024E	10A
	LS2024E	20A

Contents

1 Important Safety Information.....	1
2 General Information.....	2
3 Installation Instructions.....	3
3.1 Mounting	3
3.2 Wiring	4
4 Operation.....	5
4.1 LED Indicators	5
4.2 Setting Operation	7
5 Protection and Troubleshooting	8
5.1 Protection	8
5.2 Troubleshooting.....	9
6 Technical specifications.....	11

1 Important Safety Information

- Read all of the instructions and cautions in the manual before beginning installation.
- There are no user serviceable parts inside the controller. Do not disassemble or attempt to repair it.
- Install external fuses/breakers as required.
- Disconnect the solar module and fuse/breakers near to battery before installing or adjusting the controller.
- Do not allow water to enter the controller.
- Confirm that power connections are tightened to avoid excessive heating from loose connection.

2 General Information

LS-E series solar charge controller, with beautiful, economic, practical, simple and easy to use, etc. It has various unique functions:

- High efficient Series PWM charging, increase the battery lifetime and improve the solar system performance.
- Battery LED indicator can indicates battery situation.
- Support 3 charging options: Sealed, Gel and Flooded.
- Adopt temperature compensation, correct the charging and discharging parameters automatically and improve the battery lifetime.
- Electronic protection: load overload and short circuit, battery over discharging, over voltage, low voltage and reverse protection.
- With humanized Settings, operation will be more comfortable and convenient.
- Industrial design, wide application range.

3 Installation Instructions

3.1 Mounting

- Read through the entire installation section first before beginning installation.
- Be very careful when working with batteries. Wear eye protection. Have fresh water available to wash and clean any contact with battery acid.
- Use insulated tools and avoid placing metal objects near the batteries.
- Explosive battery gasses may be present during charging. Be certain there is sufficient ventilation to release the gasses.
- Avoid direct sunlight and do not install in locations where water can enter the controller.
- Loose power connections and/or corroded wires may result in resistive connections that melt wire insulation, burn surrounding materials, or even cause fire. Ensure tight connections and use cable clamps to secure cables and prevent them from swaying in mobile applications.
- Use with Gel, Sealed or Flooded batteries only.
- Battery connection may be wired to one battery or a bank of batteries. The following instructions refer to a singular battery, but it is implied that the battery connection can be made to either one battery or a group of batteries in a battery bank.
- Select the system cables according to $3.5\text{A}/\text{mm}^2$ current density.

3.2Wiring

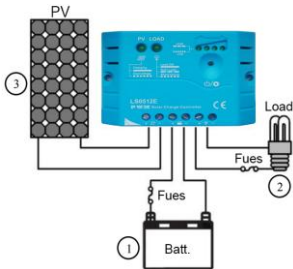

1. Connect components to the charge controller in the sequence as shown in above picture and pay much attention to the "+" and "-". Always power the battery First.
2. After power the battery, check the battery indicator on the controller, it will be green. If it's not green, please refer to chapter 5.
3. The load should be DC applicant with the same rated voltage as battery's. Controller offers power to loads through the battery voltage.

4 Operation

4.1 Features

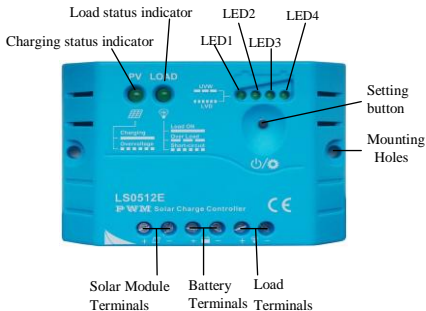

• Charging and load status indicator

Table 4-1

Indicator	Indicator Status	System Status	Note
Charging status indicator	On	Charging	Normal
	Fast Flashing	Over voltage	Refer to section 5
Load status indicator	On	Load ON	Normal
	OFF	Load OFF	
	Slowly Flashing	Overload	When the load amp is 1.25times of rated

			current for 60 seconds, or the load amp is 1.5 times of rated current for 5 seconds
	Fast Flashing	Short Circuit	Refer to section 5

●Battery status indicator(LED1、 LED2、 LED3、 LED4)

Battery LED indicator(The parameters in the table below is for 12VDC system at 25℃, for 24VDC system ,the parameters is doubled)

Table 4-2

LED1	LED2	LED3	LED4	Battery Status
Slowly Flashing	×	×	×	Under voltage
Fast Flashing	×	×	×	Over discharged
Battery LED indicator status during voltage is up				
○	○	×	×	$12.8V < U_{bat} < 13.4V$
○	○	○	×	$13.4V < U_{bat} < 14.1V$
○	○	○	○	$14.1V < U_{bat}$
Battery LED indicator status during voltage is down				
○	○	○	×	$12.8V < U_{bat} < 13.4V$
○	○	×	×	$12.4V < U_{bat} < 12.8V$
○	×	×	×	$U_{bat} < 12.4V$

“○”LED indicates on

“×”LED indicates off

“ U_{bat} ”battery voltage

4.2 Setting Operation

• Load Work Mode Setting

When the controller is powered on, press the setting button to control the load output. Press the button once, the ON/OFF status will be changed corresponding.

• Battery Type Setting

Press the setting button for more than 5 seconds, battery indicator LED1, LED2, LED3 will be flashing correspondingly. Then press the setting button to choose Sealed, Gel, and Flooded battery type, when you finish choosing, stop pressing the button, the setting is finished till the digital tube stop flashing. The parameters indicated are shown below:

Battery type selection

Table4-4

LED1	LED2	LED3	Battery type
○	×	×	Sealed lead acid battery
○	○	×	Gel battery
○	○	○	Flooded battery

“○”LED indicator on

“×”LED indicator off

5 Protection and Troubleshooting

5.1 Protection

Load Overload

If the load current exceeds 1.25 times of rated current for 60 seconds, or the load amp is 1.5 times of rated current for 5 seconds, the controller will disconnect the load. Overload must be cleared up through powering on again or pressing the setting button.

Load Short Circuit

Fully protected from load wiring short circuit (exceeds 2 times of rated current) automatically. One automatic load reconnect attempt, the fault must be cleared by reapply power or pressing the setting button.

Battery Reverse Polarity

Fully protection form battery reverse polarity, no damage to the controller will result. Correct the mistake of wiring to resume normal operation.

Damaged Local Temperature Sensor

If the temperature sensor short-circuited or damaged, the controller will be charging or discharging at the default temperature 25°C to prevent the battery damaged from overcharging or over discharged.

High Voltage Transients

PV is protected from high voltage transients. In lightning prone areas, additional external suppression is recommended.

5.2 Troubleshooting

Trouble Shooting

Table 5-1

Faults	Possible reasons	Troubleshooting
Charging LED indicator off during daytime when sunshine falls on PV modules properly.	PV array disconnection	Check if PV and battery wire connections are correct and tight.
Charging LED indicator fast flashing	Battery voltage higher than over voltage disconnect voltage(OVD)	Check if battery voltage is over high. Disconnect the solar module.
Battery LED1 indicator SLOWLY FLASHING	Battery under voltage	When load output is normal, LED status will return to ON automatically when fully charged.

Battery LED1 indicator FAST FLASHING.	Battery over discharged	When the controller cut off the output automatically, LED status will return to ON automatically when fully charged.
Load LED indicator SLOWLY FLASHING	Over load	Please reduce the load and press the button once, the controller will resume to work after 3s.
Load LED indicator FAST FLASHING	Short circuit	When the first short-circuit occurs, the controller will automatically resume to work after 10s; when a second short-circuit occurs, press the button, the controller will resume to work after 3s.
No LED indicator	battery voltage lower than 6V	Measure battery voltage with multi-meter. Min.6V can start up the controller.
No charging status LED indicator with normal connection	input voltage of solar module lower than battery voltage	Measure the input voltage of solar module, the input voltage must be higher than battery voltage.

6 Technical specifications

Electrical Parameters

Table 7-1

Description	Type	Parameter
Nominal System Voltage	LS0512E/LS1012E	12VDC
	LS1024E/LS2024E	12/24VDC
Max. batt. Volt. to the controller	LS0512E/LS101E	16V
	LS1024E/LS202E	32V
Rated Battery Current	LS0512E	5A
	LS1012E/LS102E	10A
	LS2024E	20A
Charge Circuit Voltage Drop	ALL	$\leq 0.26V$
Discharge Circuit Voltage Drop	ALL	$\leq 0.15V$
Self-consumption	ALL	$\leq 6mA$

Temperature Compensation Coefficient

Table 7-2

Description	Parameter
Temperature Compensation Coefficient(TEMPCO)*	$-5mV/^{\circ}C/2V$ (ref)

* Compensation of equalize, boost, float and low voltage disconnect voltage

Environmental parameters

Table 7-3

Environmental parameters	Parameter
Working temperature	$-35^{\circ}C \sim +55^{\circ}C$
Storage temperature	$-35^{\circ}C \sim +80^{\circ}C$
Humidity	$\leq 95\%$ N.C.
Enclosure	IP30

(The parameters in the table below is for 12VDC system at 25°C, for 24VDC system ,the parameters is doubled)

Battery Voltage Parameters

Table 7-4

Charging Parameters			
Battery charging setting	Sealed	Gel	Flooded
Over Voltage Disconnect Voltage	16V	16V	16V
Charging Limit Voltage	15.5V	15.5V	15.5V
Over Voltage Reconnect Voltage	15V	15V	15V
Equalize Charging Voltage	14.6V	-----	14.8V
Boost Charging Voltage	14.4V	14.2V	14.6V
Float Charging Voltage	13.8V	13.8V	13.8V
Boost Reconnect Charging Voltage	13.2V	13.2V	13.2V
Low Voltage Reconnect Voltage	12.6V	12.6V	12.6V
Under Voltage Warning Reconnect Voltage	12.2V	12.2V	12.2V
Under Voltage Warning Voltage	12V	12V	12V
Low Voltage Disconnect Voltage	11.1V	11.1V	11.1V
Discharging Limit Voltage	10.5V	10.5V	10.5V
Equalize Duration	2 hours	-----	2 hours
Boost Duration	2 hours	2 hours	2 hours

Mechanical Parameters

Table 7-5

Type	LS0512E	LS1012E
Overall Dimension	92.8x65x20.2mm	101.2x67x21.8mm
Mounting dimension	84.4mm	92.7mm
Mounting hole size	Φ4.5	Φ4.5
Terminal	2.5mm ²	4mm ²
Weight	74g	82.5g

Mechanical Parameters

Table 7-6

Type	LS1024E	LS2024E
Overall Dimension	101.2x67x21.8mm	128x85.6x34.8mm
Mounting dimension	92.7mm	118mm
Mounting hole size	Φ4.5	Φ4.5
Terminal	4mm ²	6mm ²
Weight	82g	151.6g

Final interpretation right of the manual belongs to our company.

Any changes without prior notice!

Version number: V1.7



BEIJING EPSOLAR TECHNOLOGY CO., LTD.

Tel: +86-10-82894112 / 82894962

Fax: +86-10-82894882

E-mail: info@epsolarpv.com

Website: <http://www.epsolarpv.com>

