

Technical manual

GWL/Modular CPM

THE CELL PERFORMANCE MONITOR
4 – 16 cells LiFePO₄/LTO

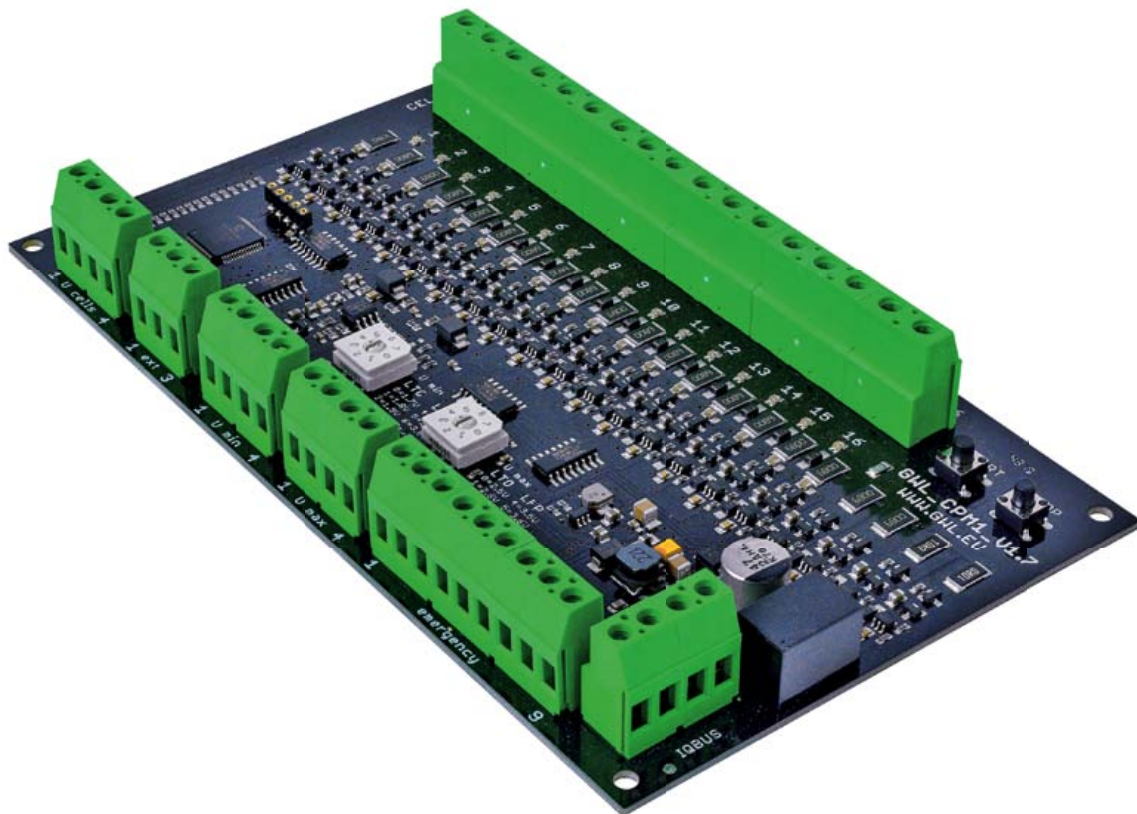

PRODUCT WEBPAGE



Module description

The Cell Performance Monitor (GWL CPM) is an easy-to-use and effective solution for the protection of the LiFePO₄ and LTO batteries from excessive discharge or overcharge.

The key features:

- When exceeding the user-adjustable minimum or maximum of any cell, CPM module closes or opens the output contacts for the relay coils.
- It brings the lowest and highest cell voltages of the cells in pack to separate outputs (for monitoring measurements or for connection of the LED display or the communication module).
- The multi-colour LEDs indicate the highest and lowest voltage cells and the operating status of the module.
- It has very low power consumption and a built-in function of battery emergency disconnection from the powered system, including self-disconnection and shutdown.
- It is part of the GWL/Modular series, i.e., it is an open-source solution that is and will be compatible with the related GWL products and with other commonly available components.
- The quality of the design, versatility and technical support options make it suitable for industrial applications and sophisticated home installation solutions.

Application possibilities

- For a battery with 4 to 16 LiFePO₄ or 5 to 16 LTO cells (any number in this range). For more than 16 cells the CPM boards can be chained, the protective disconnecting circuits may be realized with auxiliary relays.
- To control a bi-stable (dual coil) relay with a coil of full battery control voltage (or lower) by a pulse of 150 ms. One bi-stable relay can disconnect the charger, the second load, and the third (emergency) is a back-up in case the main relays fail to open.
- For controlling conventional single-coil NO/NC relays with a coil's voltage of full battery voltage. Two can be used to disconnect and connect the charger, load, or as an information to a additional system, such as a charger, converter or communications module. The third relay is back-up (emergency).
- For analog communication (Digital voltmeter, warning lights, PLC inputs).
- For digital communication via i2c protocol (protocol is available on demand).

Functions

- Powered directly from a protected battery (always from all cells, total voltage 9 V min., 60 V max.).
- Continuous measurement (200 Hz) of all cell voltages and the lowest and highest voltages output to two separate high impedance outputs (Ucells) for further processing.
- Labelling of the lowest and highest voltage cells using a two-colour LED; see the specifications.
- Choice of four fixed predefined upper voltage limits for LiFePO₄ cells and four upper voltage limits for LTO cells (Umax).
- Choice of four fixed predefined lower voltage limits for LiFePO₄ cells and four lower voltage limits for LTO cells (Umin).
- The upper and lower voltage limits are set by hardware, independently of each other, with the rotary switch, without the need for programming.
- Four outputs for single-coil relays (Umin and Umax, two without hysteresis and two with voltage hysteresis).
- Four outputs for two-coil bi-stable relays (Umin – load disconnection and connection and Umax – charger disconnection and connection).
- The single-coil relay always opens 20 seconds earlier than the two-coil relay, which can be used to relieve the load or charge before completely disconnecting the battery.
- Emergency outputs for single-coil and two-coil bi-stable relays (Uemergency) designed for emergency load disconnection if Umin and Umax disconnection fails.
- Emergency disconnection of the board's own consumption and safety disconnection from the battery cells after activation of the emergency output Umin. Else after the voltage reach 4.5V on any cell.
- Optimization of CPM consumption by divided even power from all connected cells.
- Switching the module on and off using the hardware buttons on the board.
- Switching on, off and reset by potential-free shorting of specified outputs (see the specifications).

Technical specifications

Model	4 – 16 cells LFP/LTO
Operating voltage, ranges	
Total operating voltage of the pack min. / max.	9V / 60V
Number of monitored cells	4 – 16 (any number in this range)
Cell voltage indication range	1.7 – 4.09V
Max. operating voltage at cell input	5.5V
Max. voltage of relays outputs (1,2,3,4 Umin, Umax, Uemergency)	60V
Current, power	
Own operating consumption	0.65 W
Own consumption after shutdown	lim 0 (in nanoW)
Max. continuous load of relays outputs (No. 3, 4 Umin, Umax, Uemergency)	1.5 W
Highest short-time load of relay outputs No. 1 and 2 Umin Umax Uemergency) (150ms)	10 W
Maximum output current Umin Umax (terminals No. 1, 2 and 3, 4 Ucells)	5 mA (only for high-impedance digital input)
Voltage protection settings	
Relay switch options for Umin	1.7V 1.8V 1.9V 2.0V (LTO) 2.8V 2.9V 3.0V 3.1V (LFP)
Relay switch options for Umax	2.5V 2.6V 2.7V 2.8V (LTO) 3.5V 3.6V 3.7V 3.8V (LFP)
Emergency relay switch of Uemergency, incl. power off of own consumption	0.3V below set Umin
Emergency relay switch of Uemergency, excl. power off of own consumption	0.3V above set Umax
Return to operating state	All outputs by potential-free connection of contacts 8, 9 Emergency, or by switching the board on/off. Outputs Umin 4 and Umax 4 also with additional voltage hysteresis.

Technical specifications

Times	
Cell voltage measurement frequency	200 Hz
Relay switch delay U _{min} U _{max}	Output no. 2: 35 sec, output no. 3 and 4:15 sec. If the voltage returns to set interval after the disconnection of outputs 3 and 4, the output 2 will not switch off.
Relay switch delay U _{emergency}	30 s (both terminals 2 and 3) (both terminals turn off immediately if U _{emergency} occurs within 30 s of previous U _{min} or U _{max} state reached)
Pulse length for bi-stable relay	150 ms
Switch-on delay	With button on board > 2 s; Terminals 4, 5 > 2 s
Switch-off delay	With button on board > 1 s Terminals 6, 7 > 1 s
Reset delay	Terminals 8,9 > 1 s
Dimensions, weight	
Dimensions (L x W x H)	170 x 100 x 23
Weight	150 g
Operating environment	
Operating temperature	-40°C +80°C
IP code in application	At least IP 20
Certification	
EMC	Interference and radiation resistance, protocols according to EN 61 000

Input and output description

CELLS inputs

GND	Negative (-) pole of 1st cell (the first cell is the one where the negative (-) pole of the entire battery is).
1 to 16	Plus (+) pole of cells 1 to 16 (plus pole of the whole battery is on the last plus input).

Ucells outputs

1	The voltage of the cell with the lowest voltage of all battery cells is mirrored here.
2	GND
3	The voltage of the cell with the highest voltage of all battery cells is mirrored here.
4	GND

EXT outputs

1, 2, 3	Not used.
---------	-----------

Umin outputs

1	150 ms GND pulse for bi-stable relay after switching on or resetting the board.
2	150 ms GND pulse for bi-stable relay if Umin lasts 35 seconds or immediately at any loss of voltage on any cell.
3	Output for standard single-coil relays: if are all cells within set intervals, the output is closed (connected with GND). Once the Umin is reached for whole 15 seconds or during loose of voltage on any of the cells, the GND is disconnected. The reconnection is possible only by pressing the RESET button.
4	Output for standard single-coil relays: if are all cells within set intervals, the output is closed (connected with GND). Once the Umin is reached on any cell and is maintained for 15 seconds or during loose of voltage on any of the cells, the GND is disconnected. The reconnection happens after the voltage reach „Umax minus 0,1V“ on any of the cells or by pressing the RESET button.

Umax outputs

1	150 ms GND pulse for bi-stable relay after switching on or resetting the board.
2	150ms impulse GND for bistable relay if the Umax or higher is maintained for 35 seconds.
3	Output for standard single-coil relays: if are all cells within set intervals, the output is closed (connected with GND). After the voltage of any cell reaches Umax for whole 15 seconds, the GND is disconnected. Reconnection of GND is possible only by pressing RESET button.
4	Output for standard single-coil relays: if are all cells within set intervals, the output is closed (connected with GND). After the voltage of any cell reaches Umax for whole 15 seconds, the GND is disconnected. The reconnection happens after the voltage reach „Umin plus 0,1V“ on any of the cells or by pressing the RESET button.

Emergency outputs

1	150 ms GND pulse for bi-stable relay after switching on or resetting the board.
2	150 ms GND pulse for bi-stable relay 30 seconds after reaching Uemergency (i.e., Umin minus 0.3 V or Umax plus 0.3 V).
3	Standard single-coil relay output: If all cells are within set limits, the output is closed (connected to GND). 30 seconds after reaching Uemergency (i.e., Umax plus 0.3 V or Umin minus 0.3 V) or immediately if voltage is lost on any cell, it will disconnect from GND.
4, 5	Switching on the module by shortening terminals > 2s (caution; the positive pole is on the terminals). Caution; CPM does not respond to closing 6 + 7 and 8 + 9 in case of permanent connection of these terminals.
6, 7	Switching off the board with by shortening for > 1s (all relays switch off when CPM is turned off).
8, 9	Resetting the board fault condition by shortening for > 1s (the board will not switch off, only the relays in the fault state will switch to operating state).

IQ BUS outputs

1, 2, 3, 4	Output of i2c communication for module GWL/Modular BCC (Battery Communicator and Controller) or other device (the i2c protocol is available on demand).
------------	---

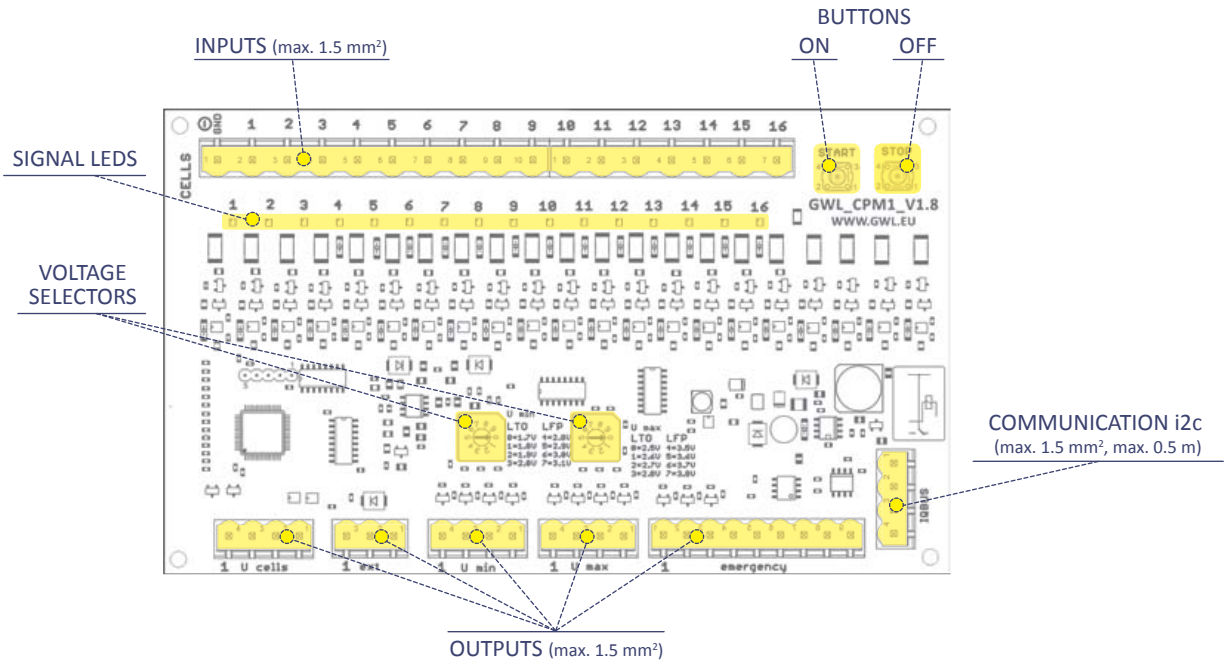

Description of controls and LED indication

Buttons

Button 1	Press > 2s = turning on the board.
Button 2	Press > 1s = turning off the board.

Potentiometers

Voltage selector Umin	Setting Umin 8 positions							
	<table border="0"> <tr> <td>0 = 1.7 V</td> <td>1 = 1.8 V</td> </tr> <tr> <td>2 = 1.9 V</td> <td>3 = 2.0 V</td> </tr> <tr> <td>4 = 2.8 V</td> <td>5 = 2.9 V</td> </tr> <tr> <td>6 = 3.0 V</td> <td>7 = 3.1 V</td> </tr> </table> <p>The zero position (0) is at 'three o'clock', then numbered clockwise.</p>	0 = 1.7 V	1 = 1.8 V	2 = 1.9 V	3 = 2.0 V	4 = 2.8 V	5 = 2.9 V	6 = 3.0 V
0 = 1.7 V	1 = 1.8 V							
2 = 1.9 V	3 = 2.0 V							
4 = 2.8 V	5 = 2.9 V							
6 = 3.0 V	7 = 3.1 V							
Voltage selector Umax	Setting Umax 8 positions							
	<table border="0"> <tr> <td>0 = 2.5 V</td> <td>1 = 2.6 V</td> </tr> <tr> <td>2 = 2.7 V</td> <td>3 = 2.8 V</td> </tr> <tr> <td>4 = 3.5 V</td> <td>5 = 3.6 V</td> </tr> <tr> <td>6 = 3.7 V</td> <td>7 = 3.8 V</td> </tr> </table> <p>The zero position (0) is at 'three o'clock', then numbered clockwise.</p>	0 = 2.5 V	1 = 2.6 V	2 = 2.7 V	3 = 2.8 V	4 = 3.5 V	5 = 3.6 V	6 = 3.7 V
0 = 2.5 V	1 = 2.6 V							
2 = 2.7 V	3 = 2.8 V							
4 = 3.5 V	5 = 3.6 V							
6 = 3.7 V	7 = 3.8 V							

Description of controls and LED indication

LEDs	
Red – Short flashing every 5 s for one cell	Signalling of normal board operation + identification of a cell with the lowest voltage in the set range U_{min} to U_{max} .
Blue – Short flashing every 5 s for one cell	Signalling of normal board operation + identification of a cell with the highest voltage in the set range U_{min} to U_{max} .
The blue and red LEDs of connected cells lit together for a short time	Identification of the connected cells after switching on the board.
The blue and red LEDs of connected cells flashing together quickly	Signalling of the board switching off.

Installation procedure and safe wiring principles

- When handling and attaching, avoid bending the plate and touching the bottom of the board with conductive items.
- Use the voltage selectors to select U_{min} and U_{max} as recommended for the type of battery used and operating conditions. Avoid rough handling and inaccurate positioning of the selector in between the positions.
- Always connect the wires and change the connections with both CPM and other connected modules off. Connection of the battery inputs should be made with high-quality and easy to disconnect parts (for example GWL/Modular Battery Link). The GND is always connected first and disconnected last. Mark the cells and clamps of battery with corresponding numbers.
- CPM can only be connected to a system in which other devices/modules are negative grounding, or neutral grounding. The system cannot be directly connected to devices with positive grounding.
- If the U_{cells} outputs are connected to the input of another active element (e.g., LAN Controller, PLC), potential equalization must not occur through these outputs. In addition to the principles outlined above, we recommend avoiding a switched-mode power supply. It is ideal to use a battery connected to CPM and connect GND for powering the connected device.
- Provide adequate protection for power and control circuits. Do not add a fuse into the GND control circuit.

Basic connection of inputs and outputs

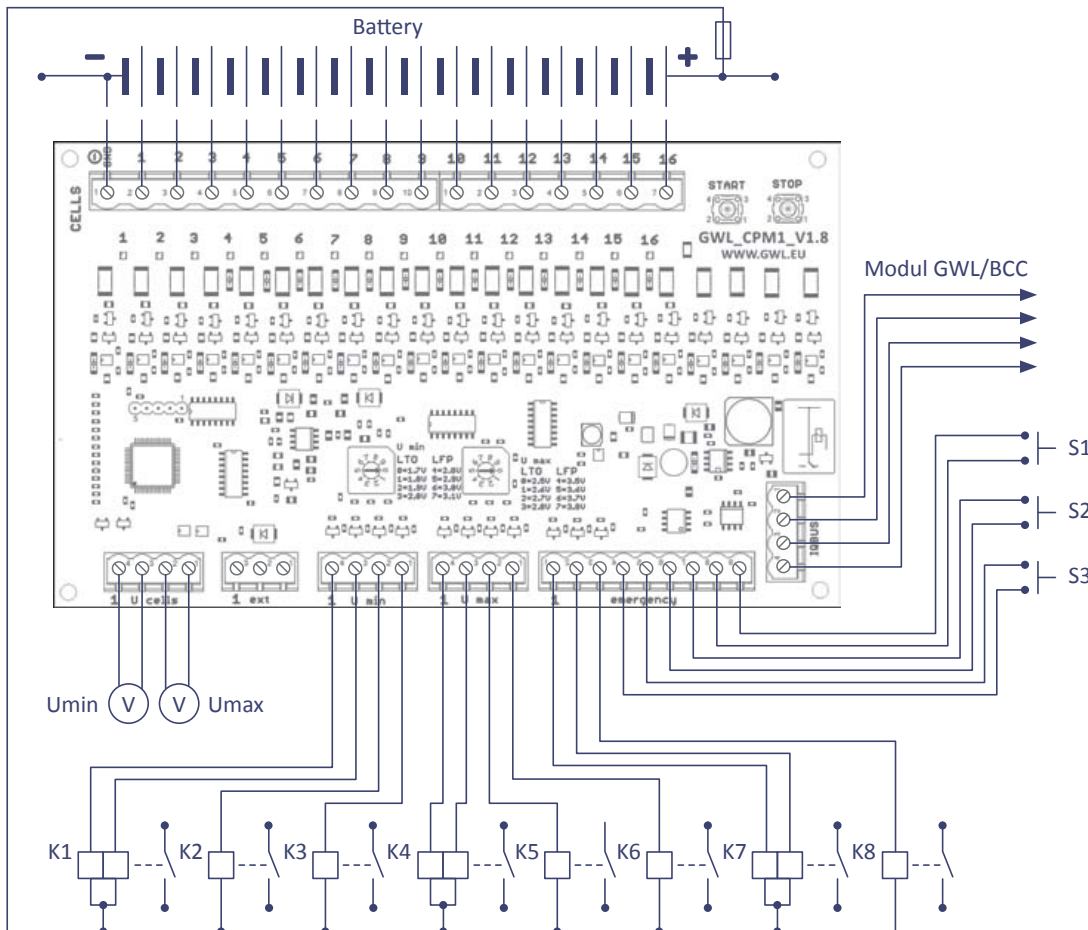

- K1** Bistable relay - opens after dropping to U_{min}
 - K2** One coil relay - opens after dropping to U_{min}
 - K3** One coil relay - opens after dropping to U_{min} . Switches after the voltage reach „ U_{max} minus 0,1V“ on any of the cells.
 - K4** Bistable relay - opens after reaching U_{max}
 - K5** One coil relay - opens after reaching U_{max}
 - K6** One coil relay - opens after reaching U_{max} . Switches after dropping to U_{min} plus 0,1V on any of the cells.
 - K7** Bistable relay - opens after changing to $U_{emergency}$
 - K8** One coil relay - opens after changing to $U_{emergency}$
 - S1** Button reset- switches any open relay when its voltage is back in the adjusted interval
 - S2** Switch off button - opens all relays and switches off the board
 - S3** Switch on button - switches on the board and switches all relays
- Relays K1, K2, K4, K7 and K8 can be closed only by RESET or START buttons.
- Relays K3 and K6 are automatically closed during voltage hysteresis or by RESET or START buttons

BATTERY – Connect the battery to GND and CELLS inputs 1–16.

GND is always negative (-) of the entire battery. Connect the positive (+) poles of each battery cell to inputs 1–16 in the electrical order from GND as they are connected in series.

Ucells – Connect digital voltmeters (not analogue with pointers), bargraphs, or use for communication with a connected device. Use only the high impedance load and follow the principles of safe connection to the connected systems described in the ‘Installation procedure and safe wiring principles’ section.

Umin – Use to open the load relay or for optical and sound indication of low battery cell voltage or to communicate with the connected system.

Umax – Use to open the charger relay or for optical and sound indication of high battery cell voltage or to communicate with the connected system.

Emergency 1, 2, 3 – Use for emergency battery disconnection.

Emergency 4–9 – Use to control the module by pulse switching (> 300ms, start, stop, reset). If inputs 4 + 5 are permanently connected, the module does not respond to commands via outputs 6, 7 and 8, 9.

Some examples of possible connections

1. CONNECTING A BATTERY WITH A DIFFERENT NUMBER OF CELLS AND RELAY WITH DIFFERENT COIL VOLTAGE

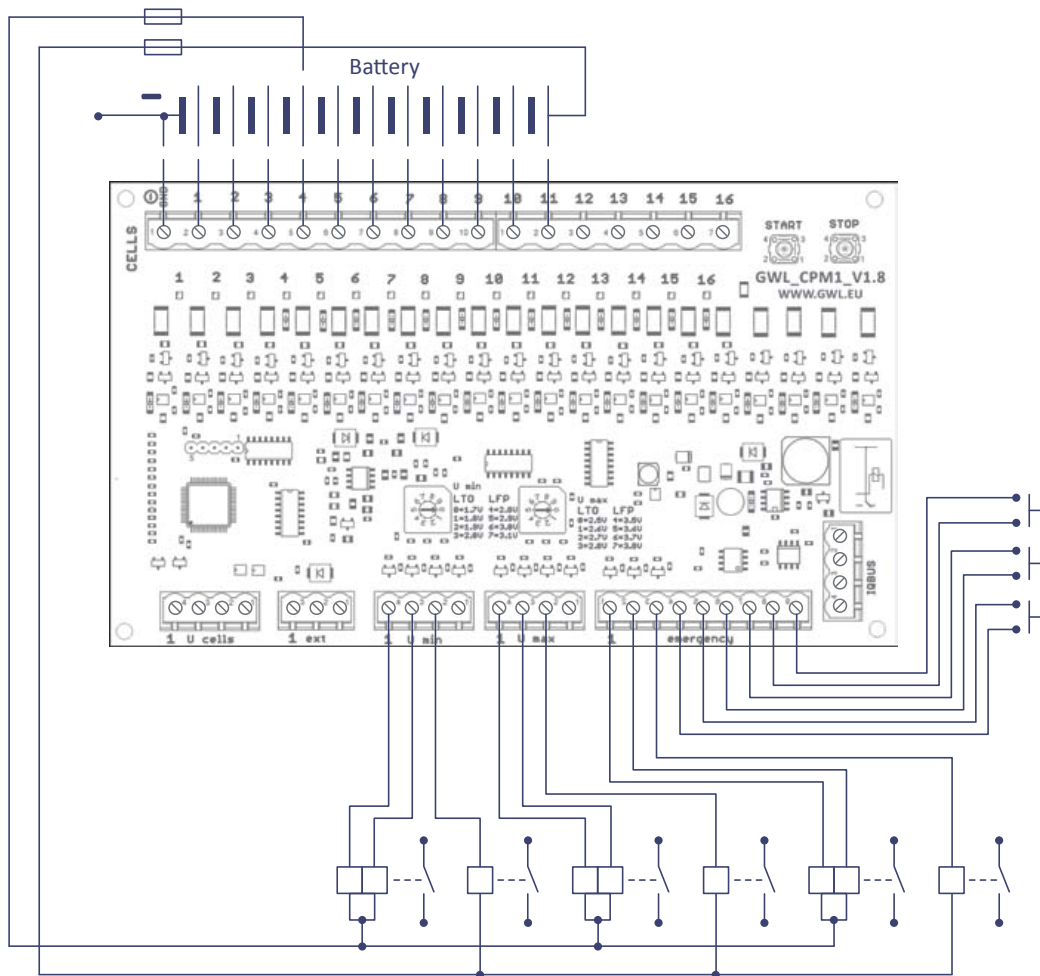

Any number of cells in the range of 4–16 can be connected; always from terminal 1 in the electrical sequence of the serial connection to the battery. A parallel battery cell connection is considered to be one cell.

Always connect the control contact of single-coil monostable relay to the last cell (total battery voltage), otherwise the cells will discharge unevenly and unbalance.

Alternatively, you can connect the control contacts of a two-coil bi-stable relay to any battery cell (part of the battery voltage), as short control pulses will not normally cause the battery to unbalance.

2. POSSIBILITIES OF COMBINED BI-STABLE RELAY FUNCTION AND MULTI-USE OF SWITCH TERMINAL

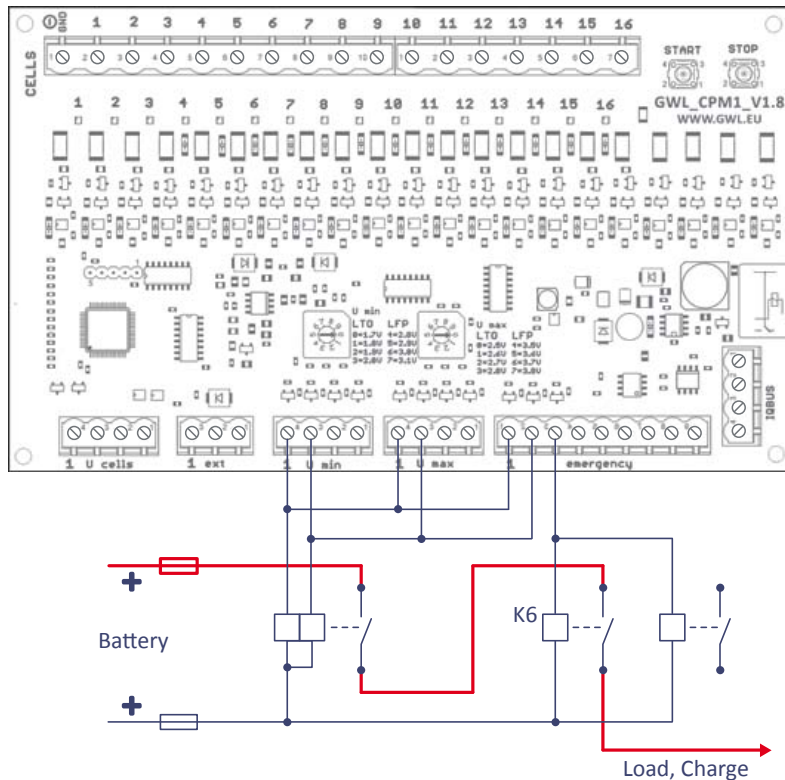

For each protection (Umin Umax Uemergency), it is advisable to use a separate relay for maximum battery protection. The combination of two or three pulse outputs per bi-stable relay reduces the quality of protection (possibility of contact bonding, coil or output failure, etc.). The combination of pulses can be used in justified cases; the electrical module structure makes it possible.

The use of a switching output for connecting multiple relays is possible if the maximum output load as specified is maintained. Otherwise, use the power contacts of an auxiliary relay.

3. CONNECTING A LARGE DISPENSABLE AND SMALL USER-IMPORTANT LOAD

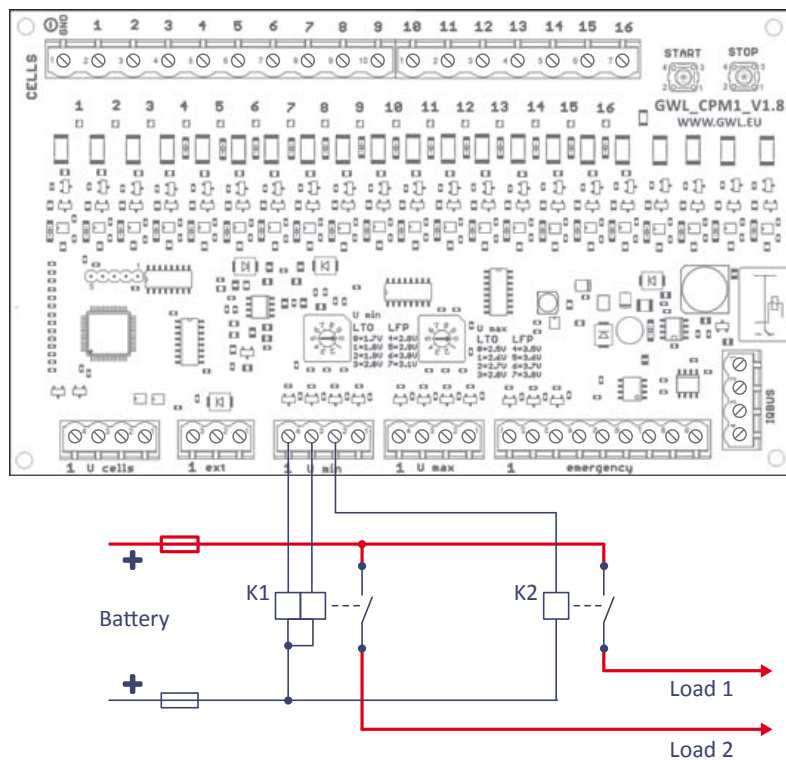

Connect high dispensable load via a standard relay, indispensable via a bi-stable relay. The high load will be disconnected first, and if the cell voltage is stable within 20 s, the important load will no longer be disconnected.

The dispensable load can be switched on again via the RESET output after recharging the battery without interrupting the important load. If the „Umin 4“ output is used, this output is automatically closed after the Umax minus 0,1V is reached on any of the cells.

4. CONNECTING HIGH-PERFORMANCE AND CONTINUOUS (CHARGING) CHARGER

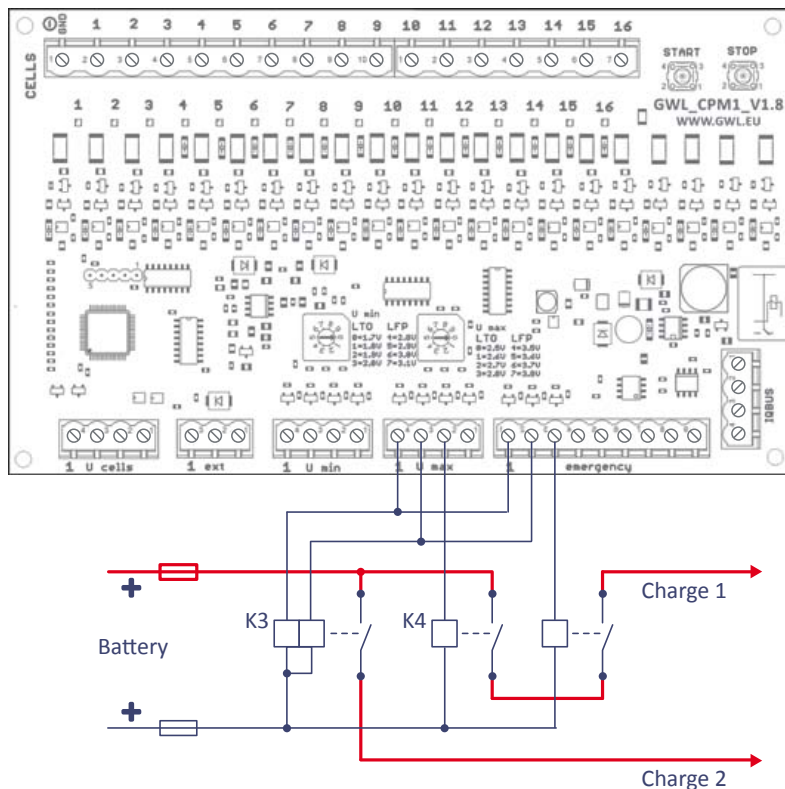

Connect the high charge current via a standard single-coil relay, low charge current via a two-coil bi-stable relay. The 'Charge 1' high charge power will be disconnected 15 seconds after reaching U_{max} , and the 'Charge 2' low charge current will no longer be disconnected if the cell voltage drops below U_{max} again within 20 seconds.

The 'Charge 1' high charge current can be switched on again using the RESET output without the low charge current being interrupted. If the „Umax 4“ output is used, this output is automatically closed after the $U_{min} + 0,1V$ is reached on any of the cells.

5. POSSIBILITIES OF CONNECTING CONTROL OUTPUTS AND MONITORING ELEMENTS

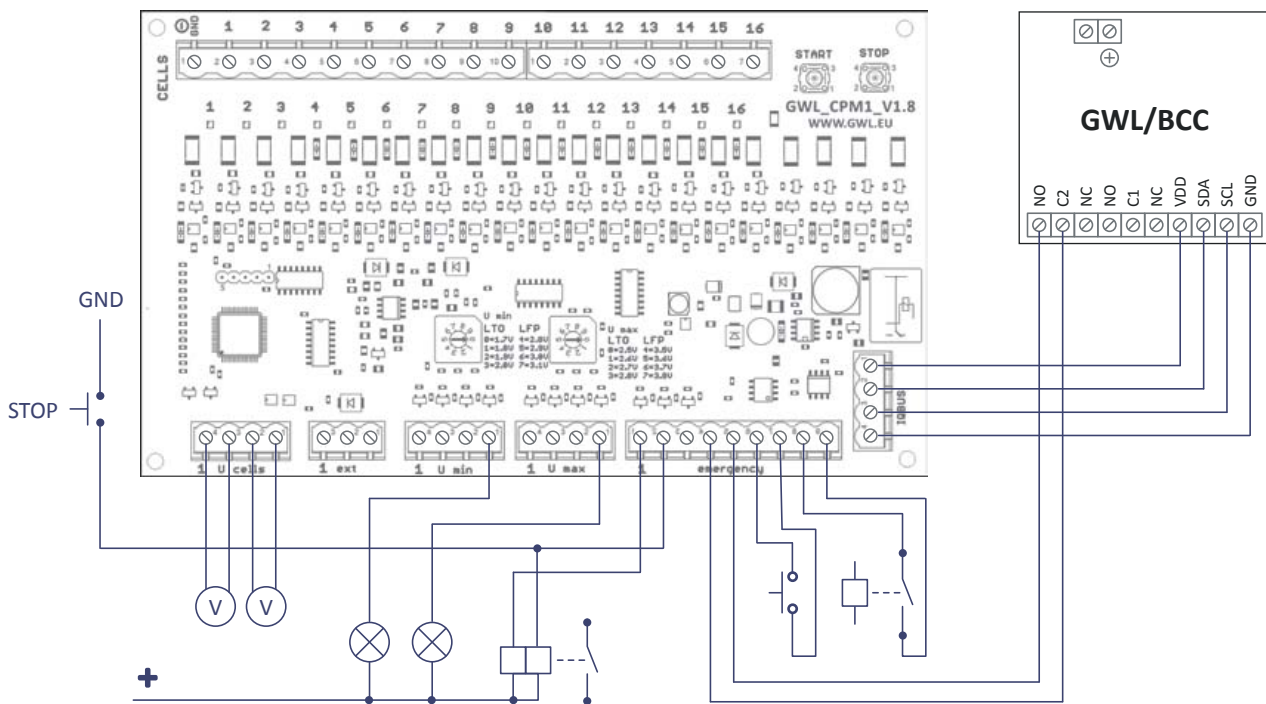

Control inputs of the standard relays (Umin 3 and 4, Umax 3 and 4, Uemerg 3) can be also used for signalization of the limit state. The bistable relays can be additionally controlled by GND impulse using the auxiliary button.

The following monitoring and controlling examples are shown in the connection diagram:

- Digital voltmeters show cell with the lowest and highest voltage.
- The LED goes out if the limit state (Umin, Umax) is reached and lights up once the voltage is within the chosen hysteresis interval.
- The emergency bistable relay is open if the limit state is exceeded by 0,3V (the battery is disconnected from system). The disconnection can also be done with external switch.
- The controlling outputs “Emergency 4 – 9 (START, STOP, RESET) can be operated by switches or potential-free contacts of auxiliary relays.
- Monitoring of all values and controlling all outputs on running CPM board is possible by using GWL/BCC module. The CPM board can also be switched off remotely. Switching off the CPM results in all outputs set to “off” state.

Powering the BCC is recommended using the protected output of battery. The BCC can switch on the CPM only if the BCC has external back-up power source or if is connected to the battery outputs before the protection. **WARNING: connecting the BCC before the CPM protection can result in complete discharge (damage) of the battery by the BCC self-consumption.**

6. POSSIBILITIES OF CONNECTING POWER OUTPUTS

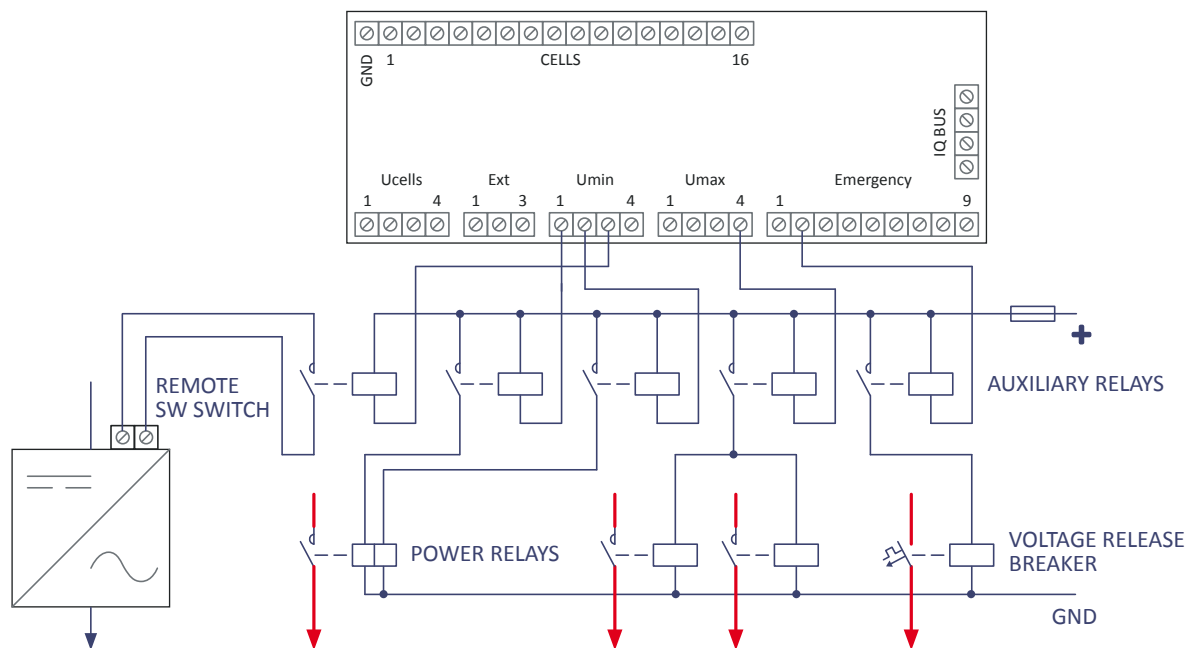

Switching power of relays coils and contactors may not exceed the switching range of CPM outputs defined in the product datasheet. For higher switching power use auxiliary relays.

While using standard relays we recommend low consumption solution (coil optimizer, smart relay...). The switching contacts of auxiliary relays can be used to amplify the impulse for bistable relay or circuit breaker voltage release.

Potential-free contact of auxiliary relay can be used for software switching off the compatible devices (Victron BP, Multiplus, MPPT Smart Solar...).

Options shown in the wiring illustration with the auxiliary relay:

- The load is disconnected by software after the “Umin” is reached. Return to working state is only by resetting or switch off and on of the CPM. Auxiliary relays are used to amplify the impulse for power bistable relay
- Chargers and MPPT regulators are disconnected by the standard power contactors once the “Umax” is reached. Reconnection happens automatically when “Umin plus 0,1V” is reached or by resetting.
- Protected battery is disconnected from all circuits after “U emergency” is reached (“Umin minus 0,3V or “Umax” plus 0,3V) by triggering the circuit breaker.

7. CONNECTING MORE THAN 16 CELLS

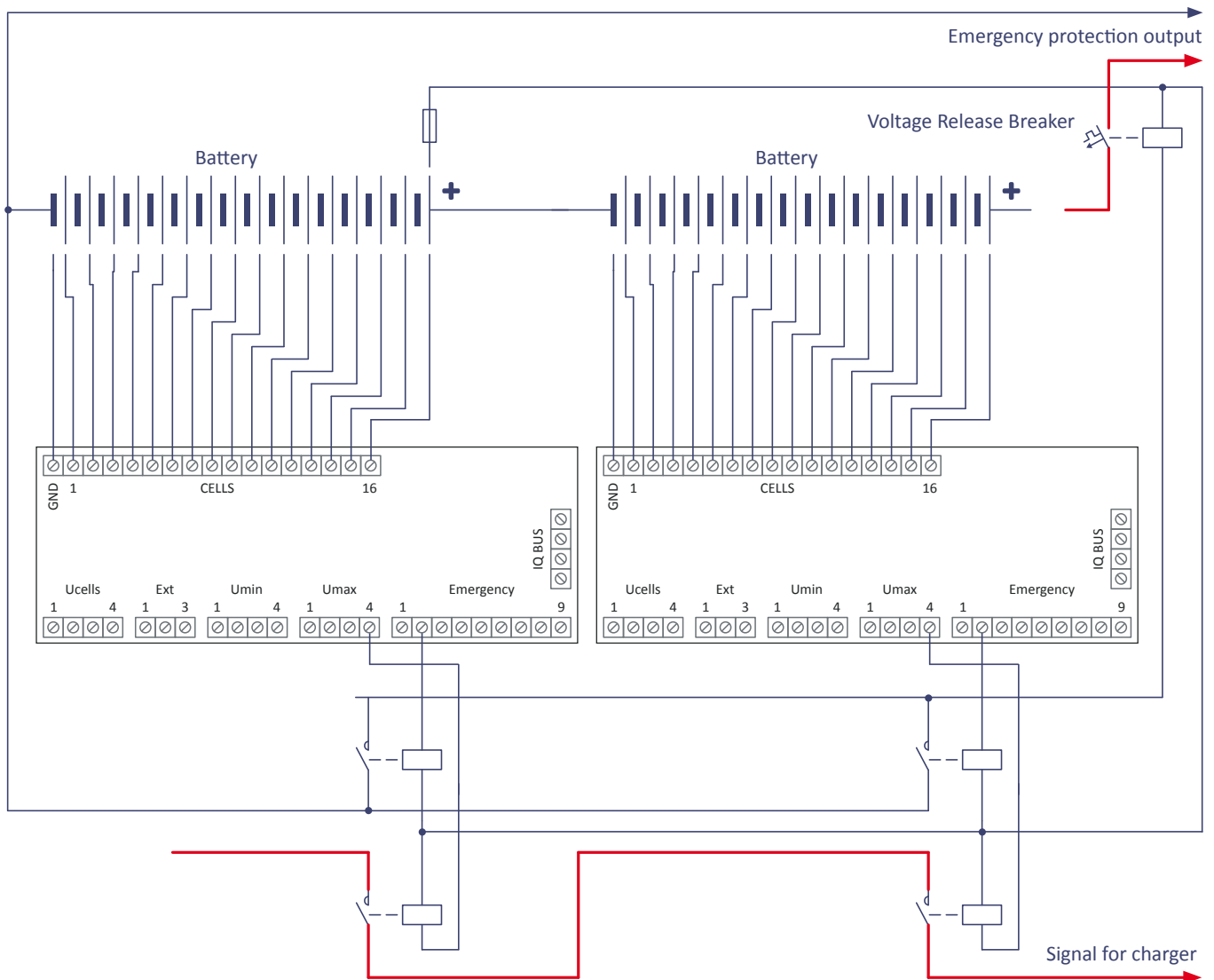

Batteries consisting of more than 16 cells must use additive connection of the CPM. Auxiliary relays must be used to control the disconnecting elements and status signalization.

Serial or parallel sorting of auxiliary relays contacts create impulses or permanent controlling voltage for the following power disconnecting elements or software controlling the devices.

Options shown in the wiring illustration:

- After the emergency state is reached on any part of the connection (any of the CPM boards), the impulse switches corresponding relay and trigger the circuit breaker voltage release on the battery output
- Reaching the “Umax” on any CPM module opens the corresponding relay and thus disconnects the power contactor or switch software of charger. Identical process can be used for “Umin” outputs to disconnect the load.

CPM Installation Examples

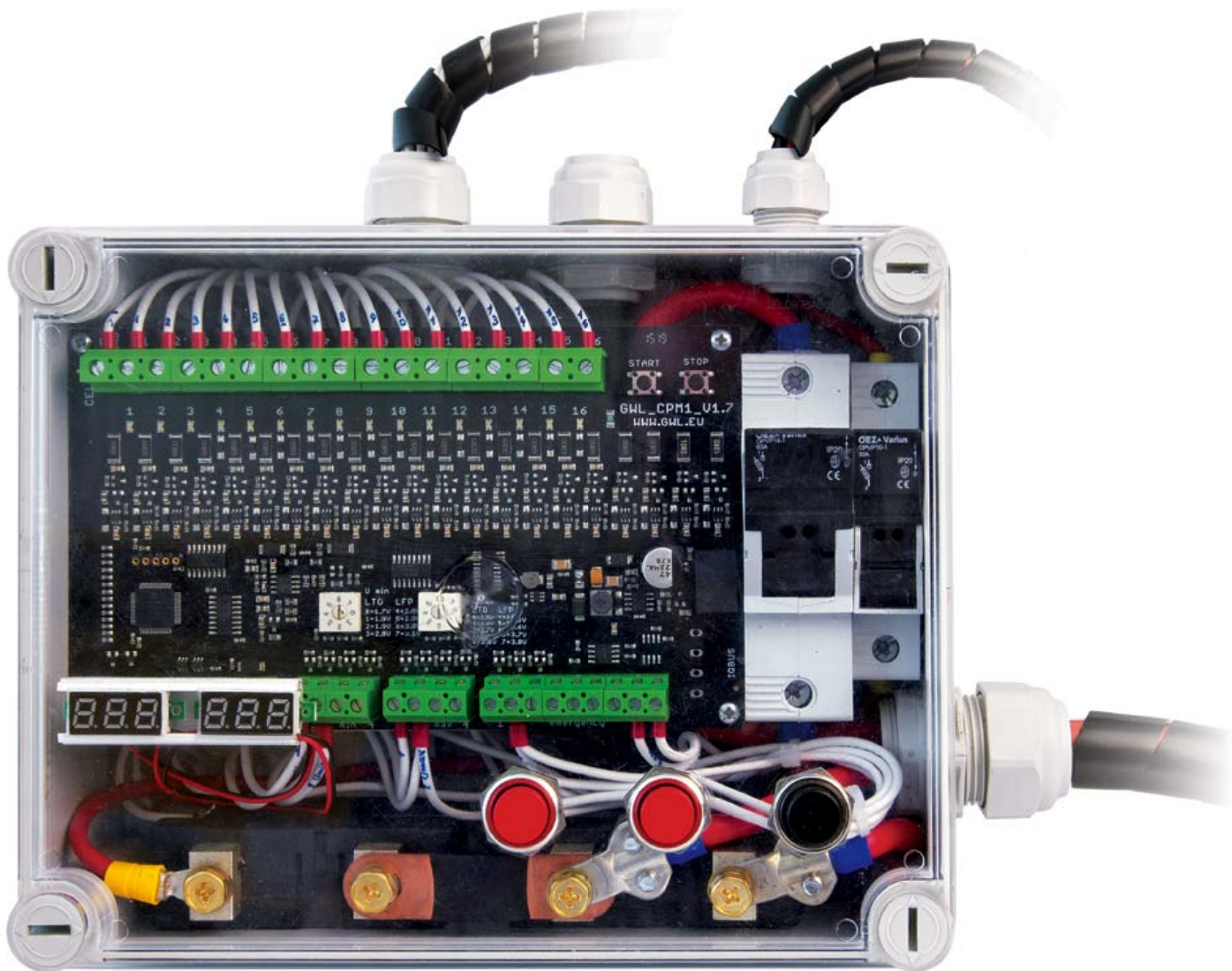

CPM Installation Examples

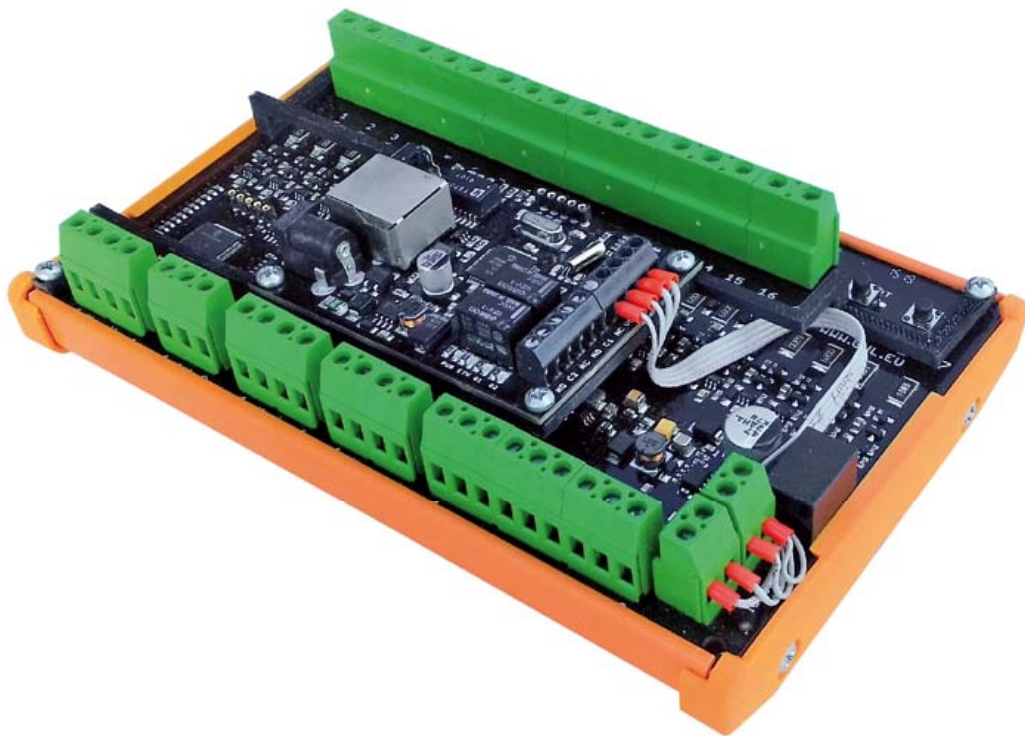

CPM Installation Examples

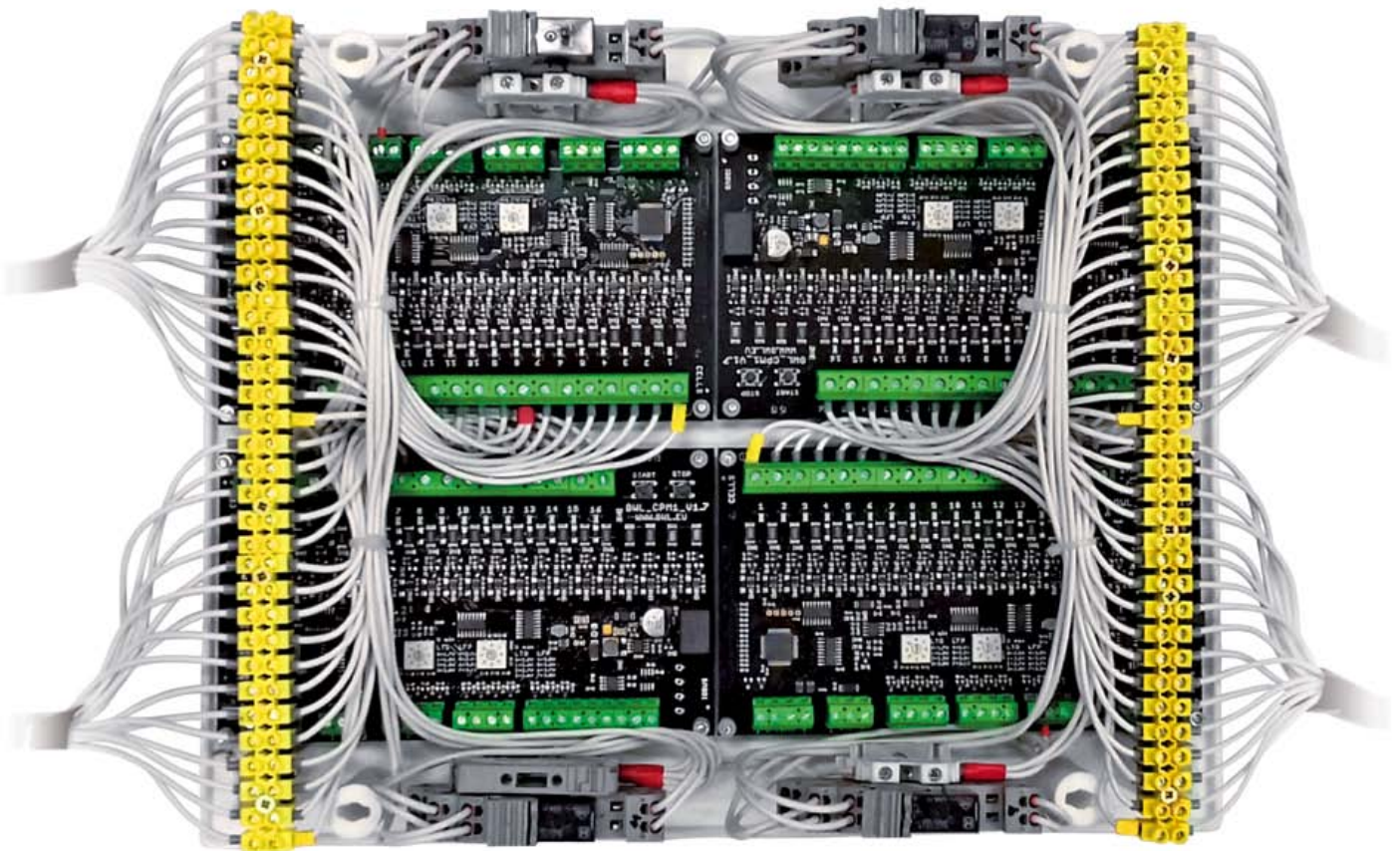

Tutorial videos

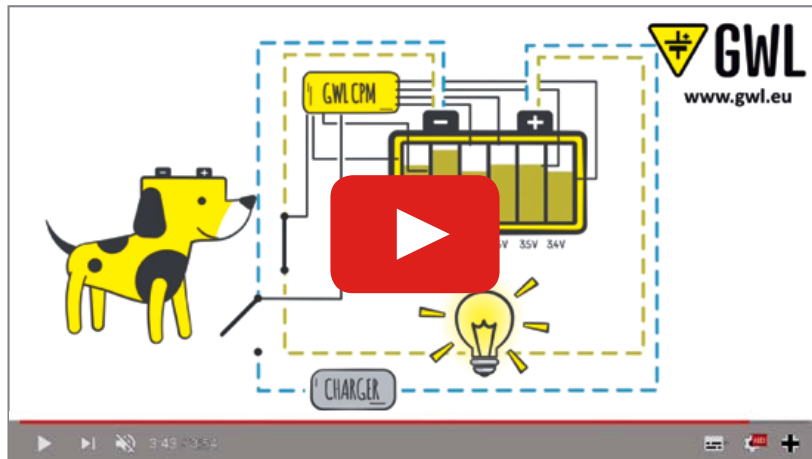

INTRODUCTION TO CPM
AND BASIC FEATURES



GWL a.s.
Průmyslová 11, 102 19 Prague 10, Czech Republic
e-mail: sales@gwl.eu, phone: +420 277 007 550