

Technical specification

Cell Balancing Module 3.3V

PCM-B01S20-417 (1S) LiFepo4

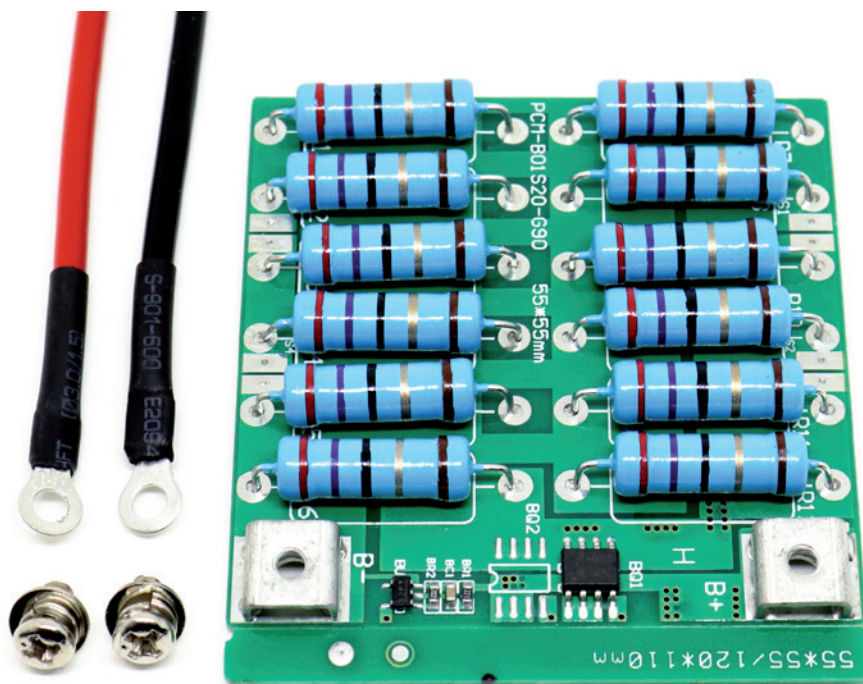

 [PRODUCT WEBPAGE](#) 

Protection Circuit Module Specifications For 3.3V Lifepo4 Battery Pack

Model: PCM-B01S20-417 (1S) LiFepo4

No.	Test item	Criterion	
1	Voltage	Balance opening voltage	$3.60 \pm 0.05V$
		Balance opening detection delay time	0.5S — 2S
		Balance close voltage	$3.50 \pm 0.05V$
2	Current	balance current	$1.60A \pm 0.1A$

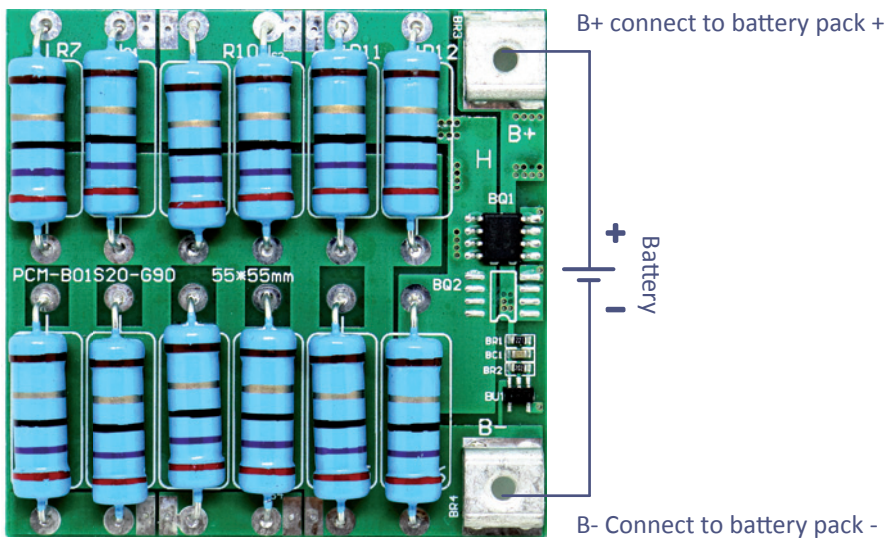

NOTE

Tolerance for balancing current = +/- 50mA



GWL a.s.
Průmyslová 11, 102 00 Prague 10
Czech Republic, European Union