

PowerSwitch^{48V}_{100A}

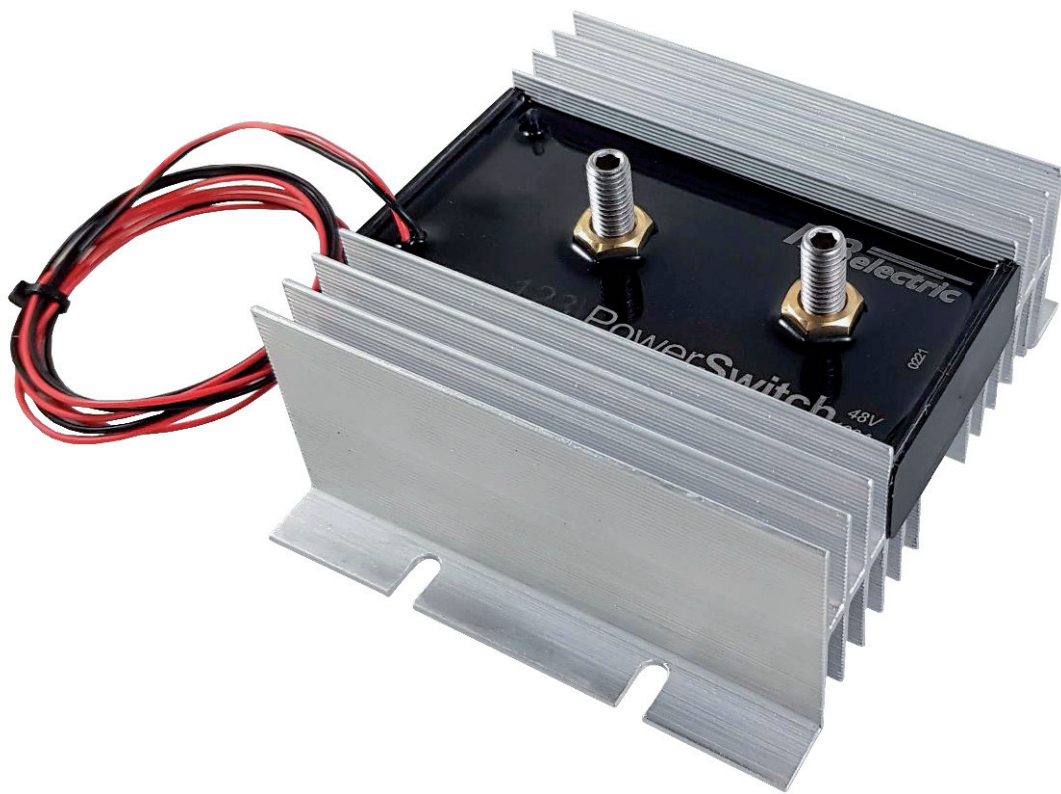

The PowerSwitch is a bidirectional solid state relay with very low power consumption when turned on. This will ensure that it can operate for a very long time, even if the battery is almost empty. A second benefit is that it can switch bidirectional currents. This means that it can be used with devices which both can charge and discharge, like a combined charger/inverter.

Electrical specifications

Description		Value / range
Maximum switching voltage		62VDC
Maximum continuous current		100A
Peak current <1 minute		200A
Operating temperature range (air)	Full load	-40 to 40°C
	70% load	-40 to 50°C
Control operating voltage		5V – 70V
Current consumption when on		0.8mA
IP rating	Electronics	IP67
	Power terminals	IPO0

Mechanical specifications

Description	Value
Total dimensions LxWxH	126 x 110 x 65mm
Power terminals	M8
Control cable size	0.5mm ²
Weight	0.5kg

Status LED

The status LED gives information about the operation of the PowerSwitch.

- When the LED does not flash, the PowerSwitch does not get any power from the two control wires. In that case, the relay does not conduct (open state).
- When the LED flashes 1x per five seconds, the relay is conducting (closed state).
- When the LED flashes fast several times and after this no flashing for 5 seconds, the relay is too warm and it will not conduct (open state). When the relay has cooled down, operation will restart.

Parallel operation

Up to three PowerSwitch units can be connected in parallel to increase the current switching. Give all power cables to each PowerSwitch about the same length to distribute the total current evenly over the units and add a fuse (max 125A) for every PowerSwitch.

Wiring examples with SmartBMS

Example with a combined charger/inverter

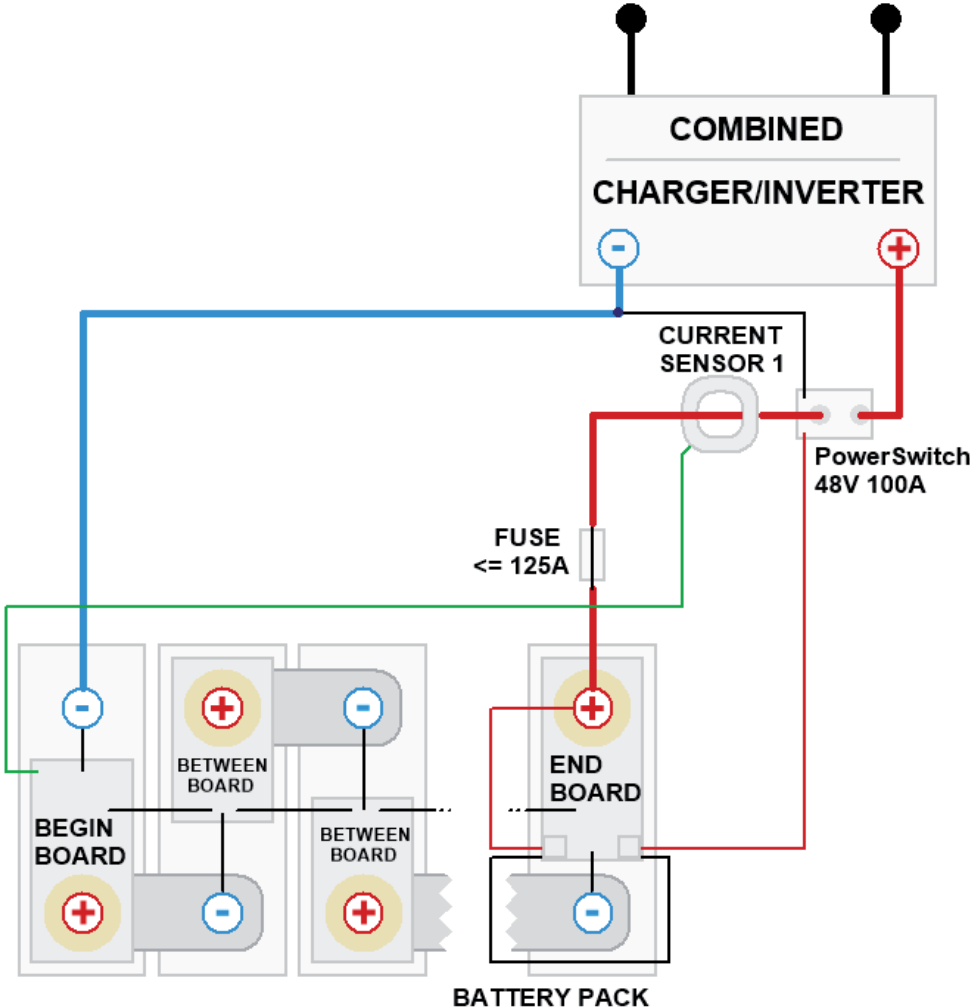

Example with a separate charger and separate inverter

