

Technical specification

Winston LFP050AHA cell



PRODUCT WEBPAGE



Winston LFP050AHA cell

Specifications

Model name	LFP050AHA	
Nominal voltage	3.3 V	Operating voltage under load is 3.0 V
Capacity	50 AH	± 5%
Operating voltage	max 3.8 V - min 2.8 V	
Deep discharge voltage	2.8 V	The cell is damaged if voltage drops below this level
Maximal charge voltage	3.8 V	The cell is damaged if voltage exceeds this level
Optimal discharge current	< 25 A	0.5 C
Maximal discharge current	< 150 A	3 C, continuous for max 15 minutes from full charge
Max peak discharge current	< 500 A	10 C, maximal 5 seconds in 1 minute
Optimal charge current	< 25 A	0.5 C
Maximal charge current	< 150 A	< 3 C with battery temperature monitoring
Maximal continuous operating temperature	80 °C	The battery temperature should not increase this level during charge and discharge
Dimensions	115 x 183 x 47 mm	Millimeters (tolerance ± 2 mm)
Weight	1.6 kg ± 50 g	Kilograms (tolerance ± 150g)
Optimal torque force	12 - 15 Nm	

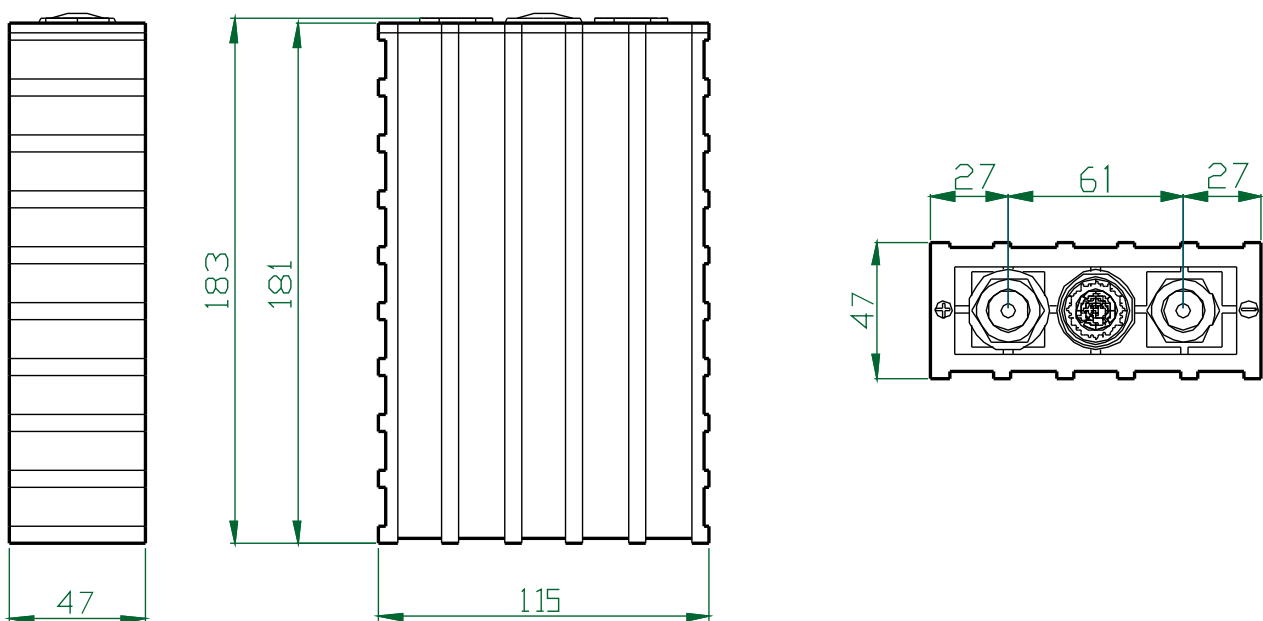

不同环境温度下LYP类电池的放电特性曲线

Discharge characteristic curve of LYP type battery under different ambient temperature

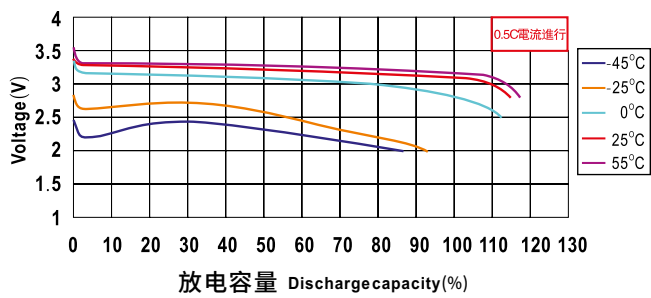

常温下LYP类电池的放电特性曲线

Discharge characteristic curve of LYP type battery under normal temperature

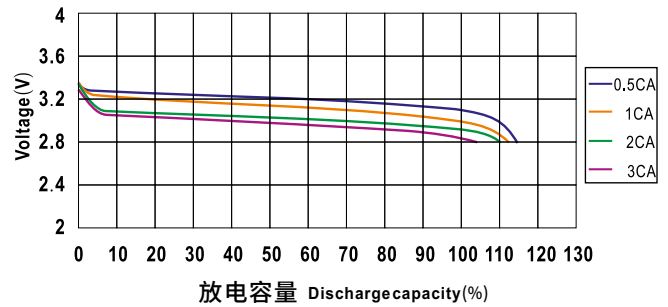

常温下LYP类电池的充电特性曲线

Charge characteristic curve of LYP type battery under normal temperature

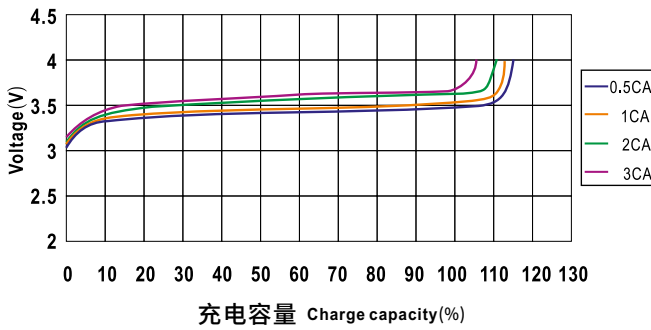

在常温下LYP类电池的存储特性曲线

Storage characteristic curve of LYP type battery under normal temperature

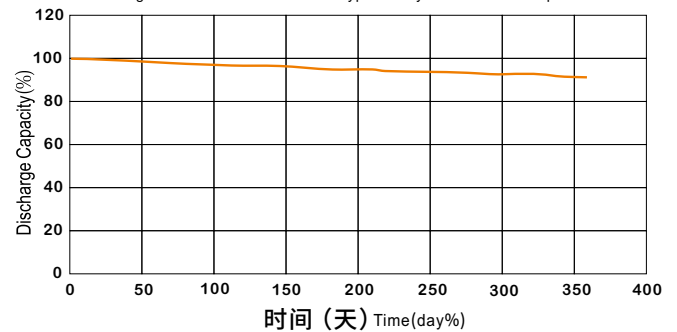

[PRODUCT WEBPAGE](#)



GWL a.s.
Průmyslová 11, 102 00 Prague 10
Czech Republic, European Union